

Allan Batty

Woodturning Notes



Includes:

- ◆ lathe speeds
- ◆ tool selection and use
- ◆ grinding and sharpening
- ◆ wax finishes
- ◆ thread chasing
- and much more . . .



\$4.95

3rd Edition

Woodturning Safety 101

Woodturning is a fun and exciting hobby for people of all ages and skill levels. The number of things you can create on your lathe with a minimal amount of time and money is limited only to your imagination. When woodturning, there are a number of safety considerations that must be kept in mind so that you can have a great time turning while being safe. Woodturning Safety 101 is intended to create safety awareness so as to prevent personal injury. We hope you will find this information helpful and that you will review it from time to time. Feel free to share this information with other woodturners you know.

Personal Safety...

1. Educate yourself on proper turning techniques, chuck operation, tool use and lathe operation.
2. Always wear a full-face shield at all times. Safety glasses are not sufficient protection against flying debris.
3. Always use a dust mask or air filtration system.
4. Wear adequate hearing protection.
5. Don't wear loose clothing, gloves or jewelry as they may become tangled with the lathe.
6. Never start the lathe before checking to make sure the spindle speed is correct for the size of work being turned. Also, make sure the work clears the tool rest by rotating the hand wheel before starting the lathe.
7. Be sure the work piece is securely mounted and is free of imperfections or poor glue joints.
8. Make sure all belt guards and covers are in place before starting the lathe.
9. Make sure the tool is on the tool rest before making a cut.
10. Always know your capabilities and work within your limits.
11. Utilize the tailstock whenever possible.
12. Always remove the tool rest support before sanding and finishing. This will help prevent injuries to your hands and fingers.
13. Do Not Overreach! Although many of today's tools have long blades, this does not mean they are designed to reach long distances over the tool rest.
14. Keep your tools sharp and properly ground. Dull tools are dangerous, as they require excessive pressure to make them cut.
15. Do not use tools for purposes they are not intended for.
16. Properly dispose of rags and do not leave finish containers open.
17. Never leave the lathe running unattended.
18. Stay alert, take frequent breaks and never operate the lathe while under the influence of drugs or alcohol.
19. Use common sense at all times. If unsure at any time, seek the advice of a woodturning expert or call us at 1-800-551-8876. We are here to help you at all times.



CRAFT SUPPLIES USA
THE WOODTURNERS CATALOG

1-800-551-8876 • woodturnerscatalog.com



Dear Friend,

These jottings are designed to jog your memory on the simpler but all important basic points which even the best of us from time to time forget.

I do hope that you find them useful as you progress in mastering a fascinating, enjoyable – and all-consuming craft.

Kind regards, and may your skew be always sharp!

Allan Batty

Allan Batty

***These notes and drawings are the copyright of Allan Batty
and may not be reproduced or copied in any way
without the author's written permission.***

©Allan Batty

CONTENTS

<i>CHAPTER</i>		<i>PAGE</i>
1	Lathe Speed	1
2	The Skew Chisel	2
3	Problems With a New Skew	2
4	Problems With Angles of the Skew	3
5	The Roughing Out Gouge	4
6	Measurements of Gouges	4
7	Spindle Gouges	5
8	Bowl Gouges	6
9	Grinding of Bowl Gouges	7
10	Problems of Angles of Bowl Gouges	8
11	Beading & Parting Tool	9
12	Parting Tool	11
13	Scraping Tools	11
14	Grinding of Scrapers	12
15	Beware of Bevel Length	13
16	Hand Rest – Height	14
17	Hand Rest – Shapes	15
18	Grinders, Grinding & Sharpening	16
19	Dry Grinding or Wet Grinding?	17
20	To Hone or Not to Hone?	17
21	Carbon Steel or HSS?	18
22	Carborundum or White Wheels?	19
23	Abrasive Wheel Dressers	19
24	Solving Problems	20
25	The Steady	22
26	Beeswax	24
27	Carnauba Wax	25
28	Beeswax/Carnauba Wax Mix	25
29	Wax Stopper Sticks	25
30	Free Hand Thread Chasing	26-29

Woodturning Notes *Allan Batty*



1 – LATHE SPEED

FOR SAFETY SAKE, it is critical that turners know how to select the proper lathe speed. Most serious accidents on lathes can be attributed to excessive lathe speeds. However, if the speed selected is too low, turning will be insufficient and take too long to accomplish.

AN area of major concern for new students is “What spindle speed should I use?”

It is important that the spindle speed selected should be appropriate to the diameter and density of the work to be turned, especially when starting with an unbalanced piece of timber.

As a general guide, the larger the diameter and/or the heavier the work piece the slower should be the speed selected.

The charts below give examples of suitable speeds for various sizes of work for both faceplate and between centers work. If you are in doubt, “slower is safer, except when crossing the road”, as an aged Scots student once confided.

Use the table below as a guide, or another way to generally determine suitable speed is to use Diameter in inches x RPM of the lathe. This should equal a number between 6,000 and 9,000 (**Dia." x RPM = 6,000 to 9,000**).

For example, the table shows a 6" diameter block should be turned at 1500 RPM.

$$6'' \times 1500 = 9,000$$

FACEPLATE TURNING

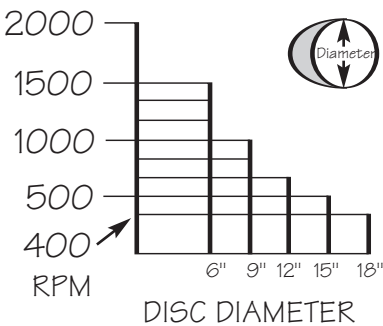

BETWEEN CENTERS TURNING

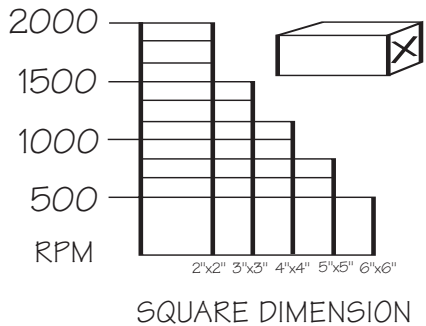

Allan Batty Woodturning Notes



2 – THE SKEW CHISEL

THE skew will produce the finest possible finish when used correctly. It is important to maintain the sharpest of edges for good results.

The skew is used in two ways in spindle work.

- 1 With a planing action where the center-to-below-center of the cutting edge slices the timber while maintaining bevel contact with the wood. (Some turners may prefer a square end chisel for this operation – see **Fig. 1**).
- 2 For cleaning end grain, pummels, rolling beads etc., when both long point and heel can be used.

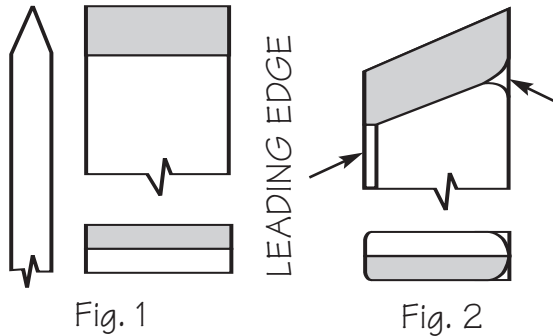

3 – PROBLEMS WITH A NEW SKEW

- 1 If you are working with the traditional rectangular-in-section skew and you are experiencing problems with the planing action then grind off or slipstone the leading edges of the skew. This will stop the skew from biting into the hand rest while planing and allow the tool to move smoothly along the rest. (See **Fig. 2**)
- 2 The older turners (I suppose I'm one now!) always ground away the top corner of the skew. (See **Fig. 2**) This acted as a second bevel, allowing the skew to plane through a shallow curve without the top corner scoring the work.

Woodturning Notes *Allan Batty*



4 – PROBLEMS WITH ANGLES OF THE SKEW

I have heard of angles from 80° to less than 25° and this tends to confuse students as to what angle to select for their own use. I have selected three different angles in common use and how I would view them.

- 1 55° is towards the hardwood end of the scale (See Fig. 5A). If you go beyond 55° say to 80° then this restricts the free movement of the tool.

For example, when turning a bead with raised detail either side, the bevel will bottom out before the cut can be completed. (See Fig. 4)

- 2 25° is towards the softwood end of the scale. (See Fig. 5C). The edge of the tool becomes too thin and thus vulnerable to chipping if used on the harder woods.

3 It is for the above reasons that I work with a grinding angle of about 40°. (See Fig. 5B). This allows me to work both soft and hard woods, but still permits access to beads with raised details etc.

- 4 Another rule is that the length of the bevel should be 1 1/2 to 2 times the thickness of the skew.

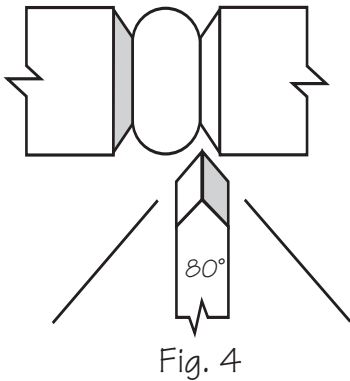
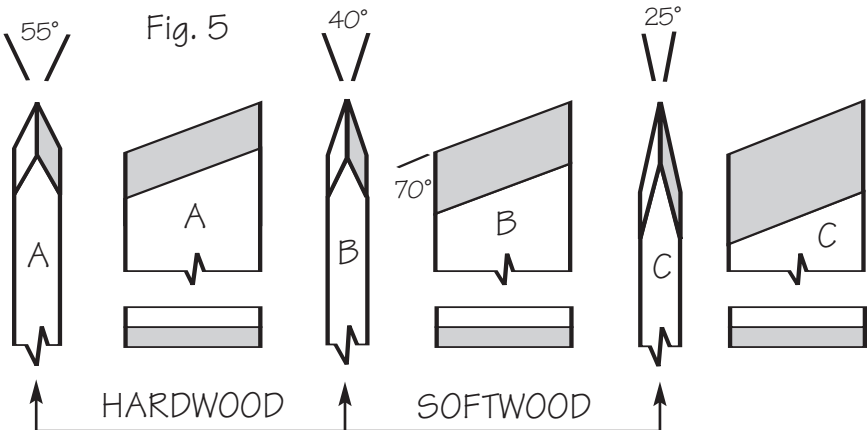

Fig. 4



Allan Batty Woodturning Notes



5 – THE ROUGHING OUT GOUGE

Sizes available 3/4" to 1 1/2"

AN essential tool for between center work (spindle turning). This tool will quickly reduce square timber to the round. Most turners favored a true half circle for this gouge with the cutting edge ground square across (See **Fig. 6**) which allows all of the edge to be utilized. As you will see from **Fig. 7**, whichever way you rotate the gouge the cutting edge remains the same. All roughing out of spindle work can be achieved with this tool and it is also ideal for long, shallow curves.

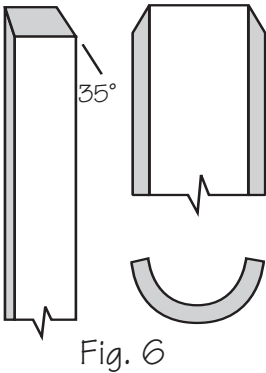

Fig. 6

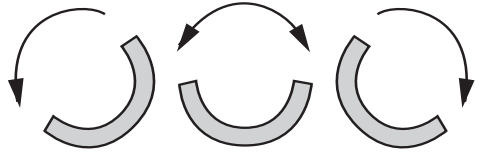

Fig. 7

Angles

I tend to grind the roughing out gouge at a longer angle, of about 35°, as this works much better on softer woods. If you are working hardwoods all the time, then retain the more common angle of 45°. My personal preference is for the 1 1/4" roughing gouge.

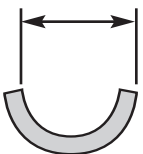

Fig. 8

6 – MEASUREMENTS OF GOUGES

ALL gouges are measured from the inside to the outside, as shown in **Fig. 8**.

Woodturning Notes *Allan Batty*



7 – SPINDLE GOUGES

Round bar-section, shallow flute

Sizes available 1/4", 3/8", 1/2"

THESSE are the main shaping tools of the spindle turner and are used for most detailed work, beads, coves, ogees etc. to which the modern round bar is particularly suited.

While these are spindle gouges, being round bar section (**Fig. 9**), they are also useful for hollowing small objects such as boxes and goblets and are ground to an angle of approximately 45° for this purpose.

(See Pages 8 & 9, Bowl Gouge Angles)

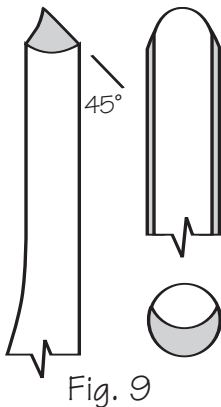

Fig. 9

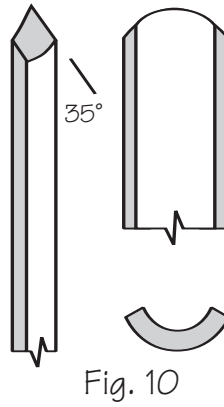

Fig. 10

Hand forged, shallow flute

Sizes available 1/4" to 1 1/2"

The old spindle turner's favorite tool, it was most commonly ground at an angle of 30° – 35° with a fingernail shape (**Fig. 10**) which made it ideal for ogees in pummels, and in long, shallow curves, general shaping and detail work. (This type of gouge was **not** used for bowl turning as it would not be rigid enough for the overhang over the hand rest which would be required when working inside the bowl.)

The larger sized 1 1/4" or 1 1/2" were frequently used as roughing out gouges by many turners. When used for that purpose it was the personal preference of the turner which decided whether the gouge was ground straight across (**Fig. 6**) or fingernail (**Fig. 10**).

The 1/2" is my favorite. I have one that I treasure which belonged to my father. (The Battys are now into the third generation of wood workers). His



gouge had lain unused for years in his box; it is stamped 'Mathieson of Glasgow', a company which no longer exists. It is a credit to them as hand forgers of their time – it is beautifully made, fits the hand perfectly and holds a keen edge. It's pre-war and I value it above all others in my workshop. It's getting short now so I use it only for ogees in pummels, a task it seems to have been made for as it follows the curve so naturally.

8 – BOWL GOUGES

Round bar-section, deep flute

Sizes available 1/4", 3/8", 1/2", 3/4"

THE above are the only sizes which were ever available to us for bowl turning. In recent years the modern round bar-section, produced in high speed steel, has superseded the traditional hand-forged bowl gouge. These not only hold a good edge but have proved superior on the more abrasive timbers.

The following descriptions of the four available gouges will help students to select the ones to suit their needs.

3/4" Bowl Gouge

This is the roughing gouge of the bowl turner. It was originally used for the rapid removal of waste wood from the larger size of bowl. The turner reduced the bowl, which was turned from wet wood, to a rough wall thickness of 1 1/2", the purpose being to speed up drying from years to months. After a period of time the bowl is remounted and re-turned to the required shape, sanded and finished.

The advantages of this method, which is used by many turners to great effect, are that not only is the drying time considerably reduced but also that the stresses are relieved during the drying process, reducing distortion and helping produce a very stable finished bowl.

1/2" Bowl Gouge

This is the jack plane of the turner; not only is it suitable for rough turning a bowl, as already described, but its rigidity makes it better suited to the turning of a larger bowl where there may be considerable overhang of the tool over the hand rest during hollowing out.

3/8" Bowl Gouge

This is the smoothing plane of the turner's trade and is by far the most popular. It is an excellent choice for most bowl turning; while maintaining the strength needed, it will leave a fine finish to the work.

Woodturning Notes *Allan Batty*



1/4" Bowl Gouge

This is a fine finishing tool when it is sharpened and used correctly. It will leave an extremely good finish to the surface, especially on areas of difficult and stubborn grain.

The main drawback with this gouge is its lack of rigidity which results in tool chatter if the projection over the hand rest becomes too great.

9 – GRINDING OF BOWL GOUGES

Fingernail

THERE are two schools of thought as to which is the better way to grind bowl gouges. Fingernail (See **Fig. 11**) or square across (See **Fig. 12**)? The following might help you make up your mind as to the better way for you.

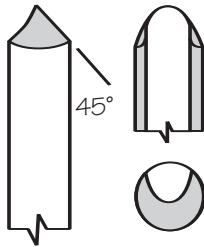

Fig. 11

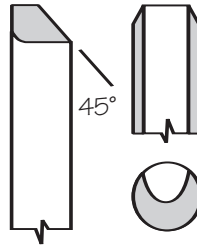

Fig. 12

In normal use of these gouges in bowl turning, one will cut almost as well as the other and both will produce excellent results. There are, though, a number of reasons that many choose to grind to the fingernail profile:

- 1 We can use the fingernail profile for shearing cuts in both bowl turning and spindle turning.
- 2 The fingernail shape makes much easier the point of entry in the hollowing out process.
- 3 While we never use the hand-forged spindle gouge for bowl turning due to its lack of strength, the bowl gouge, on the other hand, makes an excellent tool for spindle turning, general shaping, coves, beads. It really comes into its own when turning pummels in larger section spindle work, such as big newel posts, large columns etc. where a much slower speed is needed due to the massive section of the timber being turned. We would also have considerable projection of the tool over the hand rest by the time the cut was completed from square to round.



The bowl gouge ground to a fingernail profile was often better than the skew in these areas.

- 4 Another area in which the turner can make use of the fingernail profile in spindle turning is by using a shear cutting principle with bevel contact, as shown (**Fig. 13**). We can often overcome many severe interlocking grain problems using this method.

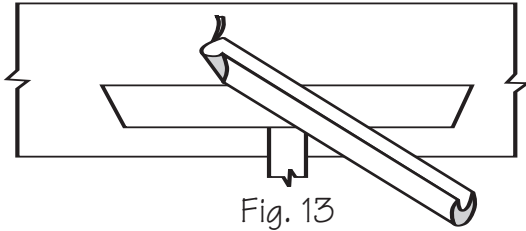

Square Across Gouge

While the square across gouge can and is used successfully for shearing cuts in both bowl and spindle turning, it is restricted in spindle work by the wings of the gouge when turning beads and coves. It comes into its own, though, and I feel it is superior to the fingernail profile, in bowl turning and in cutting end grain and is therefore my personal choice of bowl gouge shape.

10 – PROBLEMS OF ANGLES OF BOWL GOUGE

ONE of the most asked questions is “Why are there so many different suggested angles?” followed by “What should I grind mine at?” What determines the grinding angle for bowl gouges is the type of bowl you are going to be making; do bear in mind, though, the importance of maintaining bevel contact throughout the cut. You will see from the four following illustrations how each bowl determines the angle for you.

See Fig. 14 – as this is a shallow type of bowl we have no restrictions place on the gouge by the wall of the bowl, therefore none placed on the angle of the tool.

See Fig. 15 – with this bowl, the wall restricts the gouge movement. As the depth does not exceed the radius, and angle of 45° would be ideal to maintain bevel contact throughout the cut.

See Fig. 16 – here the restriction becomes greater as the depth has now exceeded the radius which, in turn, would require a shorter bevel angle of approximately 55°. This would allow the bevel to contact right to the bottom of the bowl.

Woodturning Notes *Allan Batty*

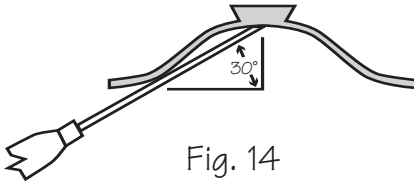

Fig. 14

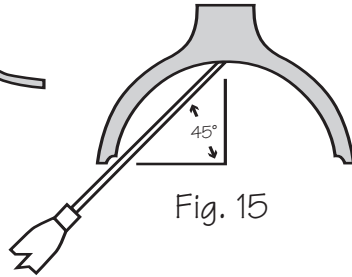

Fig. 15

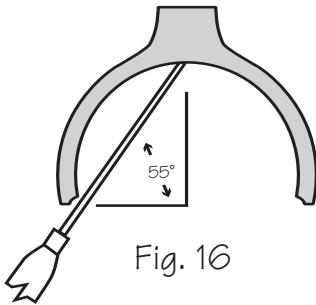

Fig. 16

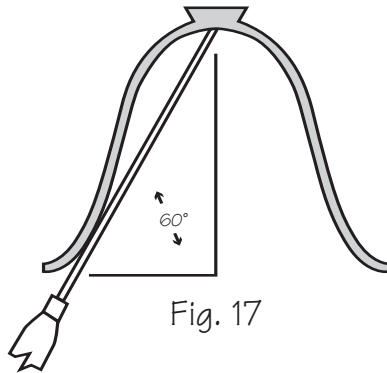

Fig. 17

See **Fig. 17** – now the depth has increased even further, which requires an even shorter angle, in this case approximately $60^\circ - 65^\circ$, to allow successful bevel contact.

You can see that the determining factor is what type of bowl you want to make. An angle of between $45^\circ - 55^\circ$ would be good working compromise.

11 – BEADING & PARTING TOOL

Sizes available 1/4", 3/8"

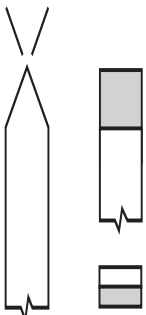

Fig. 18

THIS tool is frequently used as the square-across chisel which is shown in **Fig. 1** and proves particularly useful for planing cuts in restricted areas. It can also be used for sizing work and, as its name implies, as a beading tool. Ground as a skew, it makes a superb tool for general skew chisel work. These tools are made from square section as opposed to rectangular and this makes it a favorite choice of many turners for rolling beads. (**Fig. 18**)

I prefer to grind this tool as a skew chisel with the top corner

Allan Batty Woodturning Notes



ground away as in **Fig. 2**. The tool's rigidity makes it an ideal choice when working well over the rest in larger spindle work.

Rolling a bead correctly is one of the most difficult cuts to master because of the complex movement of the tool in use. A tip that you may find helpful in your early attempts is to raise your hand rest above center height.

You will find that this reduces the need for such a complex movement of the tool handle – you have only to roll the tool over with hardly any lift to the handle, as shown in **Fig. 19**.

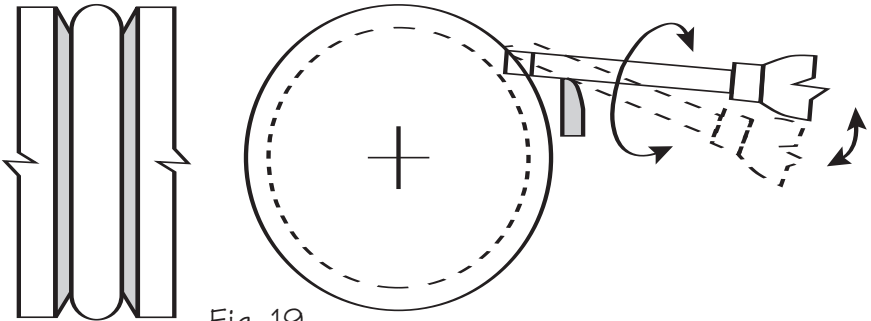

Fig. 19

If the rest is left at center height not only do you have to roll the tool and strive to keep bevel contact, but you have also to lift the handle into the horizontal position, as seen in **Fig. 20**, which is a much more difficult movement.

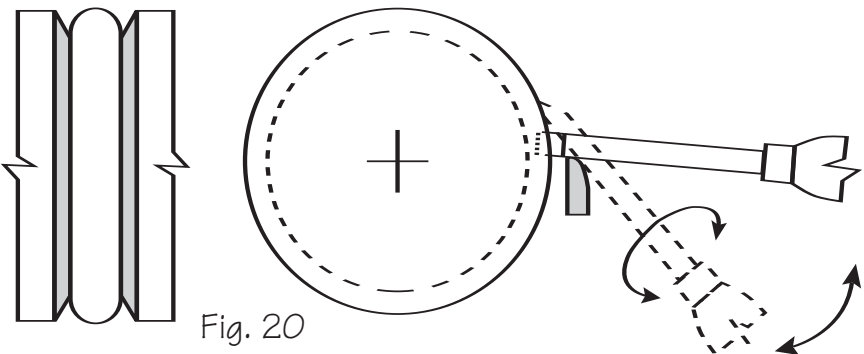

Fig. 20

Woodturning Notes *Allan Batty*



12 – PARTING TOOL

Sizes available 1/8", 1/4"

ITS ease of use makes this a popular tool with the new turner. It is designed to form grooves, work as a small, square across chisel in restricted areas, roll beads and to completely part off work. (Fig. 21) A useful parting tool 1/16" thick can be made from an engineers hacksaw blade. The purpose of off-setting the blade as shown in Fig. 22 is to save having to move the rest from its normal position as these blades are twice the width of a standard blade.

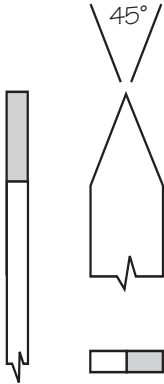

Fig. 21

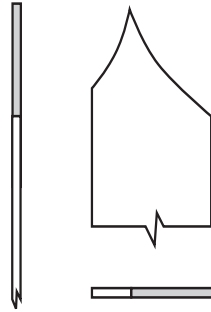

Fig. 22

13 – SCRAPING TOOLS

Sizes available 1/2" to 1 1/2"

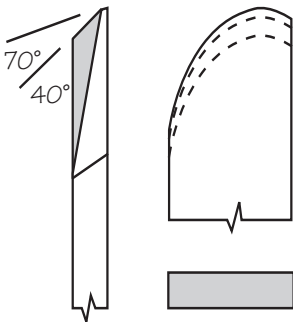

Fig. 23

SHAPES are as numerous as are sizes with these tools and are often ground to a particular shape to suit the needs of the turner as the occasion arises.

Two useful and popular shapes are:

1 Round side-cutting scraper (Fig. 23).

This is a useful shape for bowls, goblets and similar projects. There is an advantage in introducing a second bevel as shown in Fig. 23.

This not only retains an angle of 70° but it also

Allan Batty Woodturning Notes

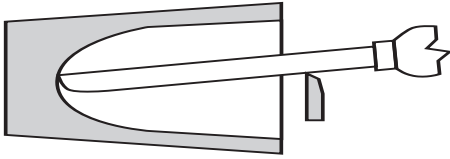

Fig. 24

offers a clearance angle when working in confined areas thus reducing the chance of the bottom of the tool scoring the work. (Fig. 24)

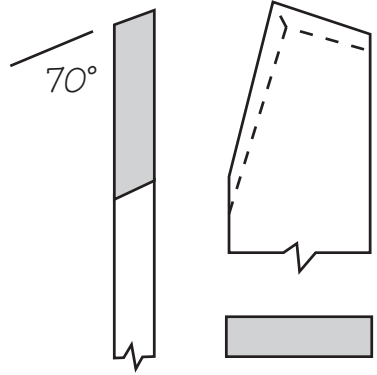

Fig. 25

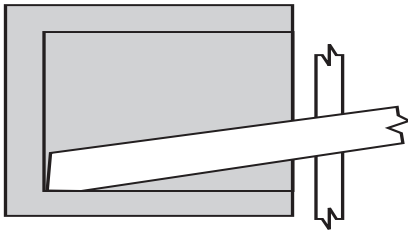

Fig. 26

2 Diamond side-cutting scraper (inside tool) (Fig. 25)

This is designed to give access into square sided boxes (Fig. 26) and various other faceplate work. The offset angle is one of pure economics. By shaping the tool to the profile shown you will retain the same shape no matter how often it is reground and it will give you maximum use of the blade. (Fig 27).

14 – GRINDING SCRAPERS

IN the normal grinding process, a burr is thrown up on the top edge of the scraper and this can be used to advantage on certain timbers.

Leave the burr on for all coarse grained timbers like oak, ash, elm etc. The burr will help cut cleanly through the fibers.

Remove the burr for all close grained or dense timbers as the burr would have a tendency to cause the tool to bite into the surface of these woods, often resulting in a catch.



Fig. 27

Woodturning Notes *Allan Batty*



The chances of catch can be significantly reduced, if not eliminated, on these timbers by oilstoning the top surface of the scraper to remove the burr, which will now cut extremely cleanly and safely, especially on timbers such as ebony, African blackwood and other very dense, exotic timbers.

Remember when using scrapers to maintain a trailing action of the blade. See Fig. 34.

15 – BEWARE OF BEVEL LENGTH

RECALL a school teacher who used an illustration to show that things are not always what they seem. He used two lines (Fig. 28) to show that although they were the same length they appeared different because the direction of the arrows created an optical illusion. I draw on this recollection because I recognize that students have a problem in this area. They often judge the angle of a tool by the length of the bevel, when this really has nothing



Fig. 28

to do with it. From Fig. 29 you can see how two different thicknesses of blade result in a longer bevel on one of them, although the angle on each remains the same, again creating an optical illusion.

Fig. 29

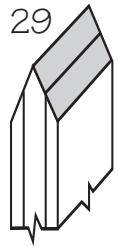

For some years now I have kept two skew chisels of different thicknesses ground to the same angles, but which look entirely different, to reinforce this point with students.

You can check your tool angles by drawing them on a piece of card, using a protractor, (Fig. 30), or you can buy a ready made angle finder.

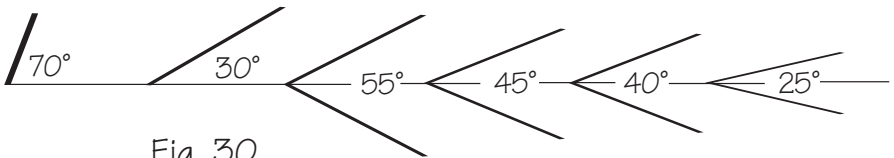

Fig. 30

I am grateful to that teacher and to the many superb tradesmen with whom I served my apprenticeship.

They have contributed in no small measure to these notes by what they taught me. I hold many fond memories of those men. One in particular I have tried to emulate as an instructor.

Allan Batty Woodturning Notes



As a young apprentice I was passionately fond of white water canoeing and built my first boat in the garage at home. During the construction Jim Bradshaw, one of the older men I was working under, kept asking me about the canoe's progress.

Came the fateful day evening, and Jim spent a full five minutes examining every detail, without saying a word.

Finally he stood up and said, "You know, lad, I would be hard pushed to match that job."

Batty's little chest puffed up with pride until Jim cleverly pointed out how one or two things "Just needed a little adjustment here and there."

What a superb teacher he was, as were so many others in the old workshops, teaching by example.

Yes, memories to treasure.

16 – HAND REST

ANOTHER very common question is "What height should the rest be?"

Spindle Turning

The honest answer would be whatever suits you, but I'll offer the following as guide lines only.

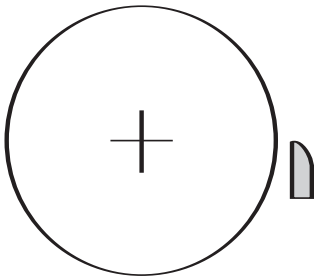

Fig. 31

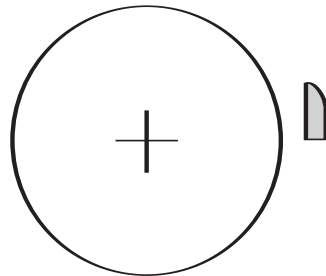

Fig. 32

Keep your rest on center height (**Fig. 31**) for all cuts except the planing cut with the skew; for this you will find it helpful to raise the rest above center height (**Fig. 32**). This position is also better for rolling beads as discussed under **Chapter 11 – BEADING & PARTING TOOL, page 9**.

Many of the older turners tended to work with the rest above center height. This saved having to move the rest at any time, although it made certain cuts, such as coves, parting off etc., more awkward.

Woodturning Notes *Allan Batty*

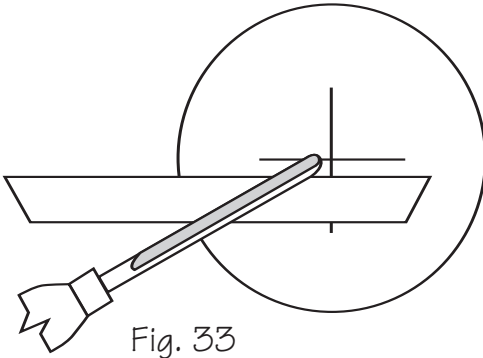

Fig. 33

Bowl Turning

Here, the rest height is dictated by the tool which you are using i.e. when using **gouges** the rest has to be low enough to allow the gouge to reach the center of the work. (Fig. 33).

When using **scraping tools**, the height of the rest has to allow the tool to reach to the center of the work while maintaining a trailing action with the blade. (Fig. 34).

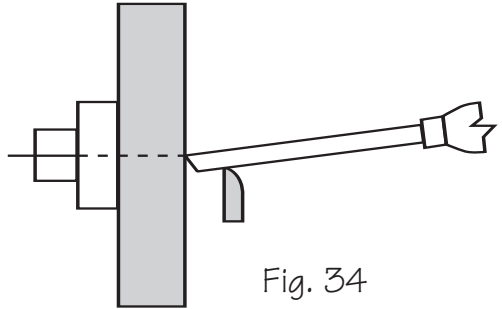

Fig. 34

Use these guides lines until experience dictates what is the best position.

17 – HAND REST

Shapes

THESE are many and varied; some are not suitably shaped or not rigid enough for our requirements. The worst I have seen was on an imported lathe. The rest had raised numbers on the top edge, dividing it into inches, which completely hindered the smooth passage of the tool. (The numbers were quickly filed off!)

An excellent rest shape is shown in Fig. 35. This was, and still is, the favorite rest shape for turners. Being straight along its length allows the hand to smoothly move backwards and forwards. The curved top gives a natural fulcrum when the tool is raised or lowered in the execution of a cut.

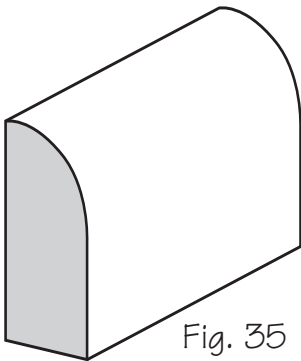

Fig. 35

Allan Batty Woodturning Notes



18 – GRINDERS, GRINDING & SHARPENING

MY earliest memories of learning to grind tools is as a fifteen year old apprentice, standing facing a 36" diameter sandstone, driven off an overhead shaft and trying to master freehand grinding on a very uneven surface. I can still feel the water running down my arms; I finished up soaking wet as the huge stone revolved deluging me in water. Not a pleasant task in winter, nor were oilskins provided!

My early attempts at this most important aspect of my trade were disasters – the tools regularly ended up with more facets than a cut diamond. It took me a long time to master freehand grinding and I therefore know how frustrating this can be for students.

I tell you all this not discourage you, but to reassure you that I now know there is a much easier way to sharpen tools. (No, you don't have to send them by parcel post to me...)

Nowadays I use a 6" double-ended bench grinder with 60 grit white stones on each end and adjustable rests. The allows the student to set the rest and any angle to suit the particular tool being ground, therefore offering full support

during the grinding operation. Hey, presto, the perfect bevel every time! (See Fig. 36).

Time spent practicing in this department is time well spent; you will get good results every time, your tool bevels will no longer look like cut glass, your turning will improve – and so will your confidence.

You will be saved a lot of frustration and you will then find that your ability to freehand grind will follow quite naturally.

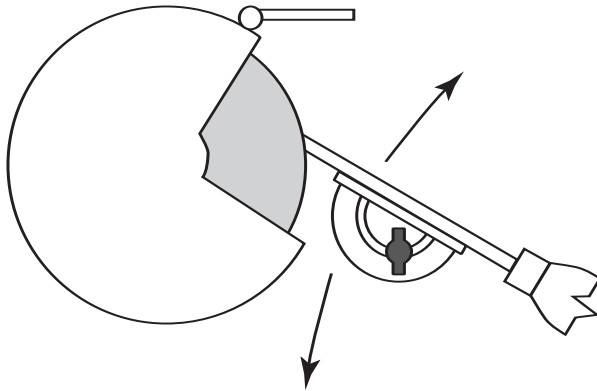

Fig. 36

Woodturning Notes *Allan Batty*



19 – DRY GRINDING or WET GRINDING?

Dry Grinders – Advantages

- 1 Reasonably inexpensive.
- 2 They have a fast cutting action and will remove metal quickly, which is ideal for sharpening a new tool or adjusting a bevel as the need arises.

Dry Grinders – Disadvantages

- 1 Some grinders come with very coarse, carborundum wheels.
- 2 Care is needed so as not to overheat the tool in the grinding process. (These machines run at around 3000 rpm). There is a risk of burning the edge and drawing the tool steel.
There is more danger of this happening in your early days of learning to sharpen, especially in freehand grinding as you search each time to place the bevel each time in its correct position on the revolving wheel.

Remember that eye protection is essential when dry grinding.

Wet Grinders – Advantages

- 1 As wet grinders are designed to run much slower (max. 150 rpm, depending on wheel diameter) and to run in a trough of water, this keeps the tool cool during the grinding process which eliminates any risk of overheating.
- 2 The finished cutting edge which can be achieved is excellent and in woodturning honing would not be required.

Wet Grinders – Disadvantages

- 1 They are expensive.
- 2 They are too slow if a lot of metal has to be removed, as in when shaping a new tool.

Pay your money and take your choice. If you can afford both you will have the ultimate in grinding equipment.

20 – TO HONE OR NOT TO HONE?

TH**ERE** has been much controversy over this question and I do not wish to add fuel to the fire except to explain what I do – and why. I served my apprenticeship in the coach-building and cabinet-making trades and this instilled in me the need to oilstone all my cutting tools with loving care, finally stropping the edges, with either the hand or a piece of soft leather, until they were like razors.

Allan Batty Woodturning Notes



I have a different approach in wood turning. I work almost straight from the dry grindstone (fine wheels) except for an occasional rub with a slip-stone in the flute of gouges and a strop with a piece of leather which hangs from my belt. (It hangs there so I don't have to burrow amongst the shavings looking for it.)

My skew chisels are stropped frequently with this same piece of leather after grinding and, depending on the timber, given a light honing; this gives me a super edge which lasts.

The reason for this simplified grinding and sharpening is this. With a piece of 2" diameter timber turning at 2000 rpm the tool is cutting approximately 1000' of timber per minute, more than my cabinet-making chisels would do in a month, which means that my wood turning tools need to be ground much more often in a day than my cabinet-making tools ever would. If care is taken in the grinding process we can produce a very acceptable cutting edge without extensive honing.

One of my most treasured possessions is a one hundred year old lathe, with an 11' long wooden bed, which I have lovingly restored to its former glory. I have retained the original bed bar which now hangs in place of honor above the restored lathe. This bed bar bears silent testimony to the fact that generations of wood turners had worked straight from the grinder, deburring their tools by jabbing them into the wooden bed, which is well and truly scarred by the practice. (Try that on a modern steel lathe!)

Pat, my wife, jokingly says that I think more of that old lathe than I do of her. How could that be? "Big Bertha", my lathe, cannot cook, keep me warm at night nor feed me on chocolate biscuits...

21 – CARBON STEEL or HIGH SPEED STEEL?

MOST of my working life has been spent using carbon steel tools but since the introduction of high speed steel (HSS) I have come to favor it for the following reasons.

- 1 Less time spent on sharpening – a sharpened edge will last about six times longer.
- 2 The tool will therefore last about six times longer.
- 3 The danger of accidentally drawing the temper of the steel during regrinding is greatly reduced, if not eliminated.
- 4 The student will do little or no harm in practicing sharpening on HSS unlike carbon steel which can be spoiled by faulty grinding. I have seen students actually blue the edge of carbon steel tools by turning at too high a speed and pressing too hard with the bevel onto the work.

Woodturning Notes *Allan Batty*



22 – CARBORUNDUM or WHITE WHEELS?

HIGH speed steel can be ground on the conventional dry grinder with carborundum wheels. However, the normal carborundum wheels tend to glaze quickly, resulting in lost efficiency which will create overheating in the tool.

It is for this reason that I favor a white wheel. (Soft bonded aluminum oxide). A soft bonded wheel breaks down more quickly and significantly reduces glazing by revealing fresh, sharp particles of abrasive.

For re-grinding high speed steel a 60 grit or 80 grit wheel is recommended.

23 – ABRASIVE WHEEL DRESSERS

ALL grinding wheels will glaze with constant use as particles of metal become embedded in their surface. This reduces the efficiency of the wheel, resulting in overheating of the tools which are being ground. It is therefore important to dress the grinding wheel to expose fresh grit and thereby restore its grinding ability. There are three tools available for this purpose – they are designed to true, sharpen and shape the grinding wheel.

1 Star wheel dressers

These are easy to use and are relatively inexpensive.

2 Diamond wheel dressing tool

These are easy to use, and can be expensive but the WD300 Diamond Dresser sold by Craft Supplies U.S.A. is a wonderful tool for keeping grinding wheels flat across the face. The 1" width will dress most wheels in one pass, and the dresser will last a lifetime, making other wheel dressers obsolete.

3 Devil stone – 6" x 1" x 1"

This is a composite stone, very easy to use by simply placing on the rest and passing across the face of the grinding wheel. This will not only rapidly de-glaze but will also true your wheel.

Important points to remember

- 1 Never** use the side of the grinding wheel – it is not designed to take sideways pressure.
- 2** When replacing a grinding wheel you **must** ensure that it is designed to run at the speed of your grinder. This information should be on the paper washers that come bonded to the sides of the wheel. If in doubt, check with your supplier or manufacturer.



24 – SOLVING PROBLEMS

Spindle turning

Spiralling towards the headstock

- 1 Check your bearings.
- 2 Possible drive center damage due to constant hammering into the work piece resulting in a poor fit within the morse taper.

Spiralling towards the tailstock

- 1 This is a common problem and is probably due to a faulty revolving center.
- 2 If you are using a dead center, the work piece may require tightening between centers due to the dead center burning its way into the work. Keep the dead center lubricated with wax – this will help stop the problem arising.

Each of the above can contribute to the following:

Tool Chatter

- 1 Check all the points mentioned above.
- 2 The bevel is not in contact with the work.
- 3 The tool is too thin, resulting in the bland flexing in use.
- 4 The work is too thin and needs support. (See **25 – THE STEADY**).
- 5 The rest may need to be tightened.
- 6 The rest may be flexing at its extreme ends due to lack of rigidity.
- 7 The tool overhang may be too far over the hand rest.
- 8 The work piece may need to be tightened between centers.

Bowl turning

Spiralling and/or tool chatter

- 1 The work is insecurely mounted onto the screw chuck, or faceplate, resulting in unwanted movement of the work piece.
- 2 The bevel is not in contact.
- 3 The rest may need to be tightened.
- 4 The rest may be flexing at its extreme ends due to lack of rigidity.
- 5 Pressing too hard with the bevel.
- 6 Trying to cut too quickly.
- 7 Shavings jammed between the tool and the work causing the bevel to leave the work.
- 8 The tool may be flexing due to it being too thin for the distance of the blade projection over the rest.

Woodturning Notes *Allan Batty*



9 The bowl wall thickness may be reduced to a point where it needs support from your left hand on the side of the bowl while the cut is in progress.

10 Trying to take too heavy a cut.

11 An unusual problem I have encountered is one of the chuck not seating properly due to a faulty headstock spindle. (See **Fig. 37**).

This happened to me at a seminar and it was some time until I found the source of the problem. It was solved by turning down the offending part of the spindle using the diamond side-cutting scraper. (See **Fig. 25**).

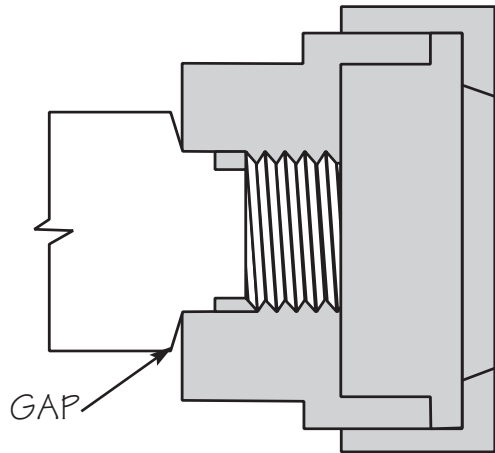

Fig. 37

A problem common to bowl and spindle turning is that the tool is not sharp enough.

Allan Batty Woodturning Notes

25 – THE STEADY

THE success or failure of this type of steady lies in understanding its use. The purpose of the steady is to support thin, slender work as it revolves and to resist the pressure placed upon it by the tool.

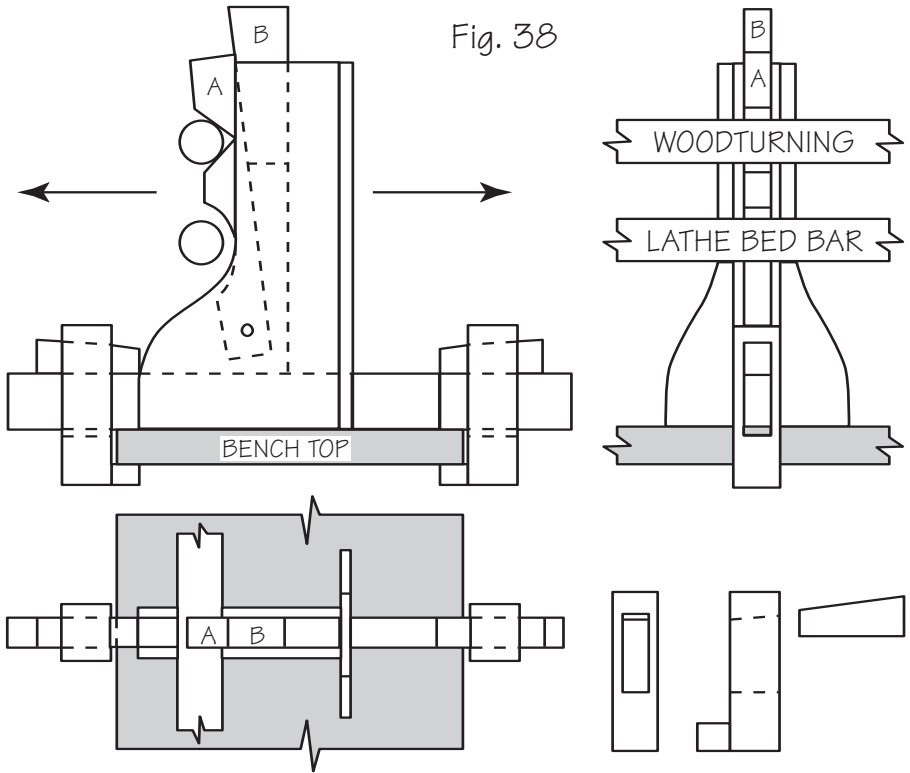

To achieve this it is important to have two points of contact within the “vee” as shown in **Fig. 38**. Failure to do this will result in thin work moving away from the tool which in turn renders the steady useless.

Another common fault with a steady is to make it one fixed position on the bench without making provision for moving the steady backwards or forwards in the direction of the arrows as shown in **Fig. 38**.

This means that the “vee” will work with only one given diameter because the **Brace A** moves in a downward arc, therefore any change in diameter again renders the steady useless.

Woodturning Notes *Allan Batty*



By making provision for movement, as shown, the steady can be adjusted backwards and forwards so as to keep the two points of contact with the revolving wood at any time.

This makes the steady useful for any diameter from 3/8" to 3".

With a little ingenuity, a steady may be made for any lathe.

Useful Points

- 1 The work must be brought to the round first. With extremely thin work it can be brought to the round at the point of steady contact by lightly turning down the work with a small gouge, gently supporting the work with the left hand.
- 2 You can reduce friction and burning at the point of steady contact by rubbing beeswax/carnauba wax onto the revolving surface.
- 3 By making the top **Wedge B** a reasonably tight fit it will retain its position during the turning process without riding up.



26 – BEESWAX

Block

SO well known as not to require description, beeswax produces best results if it is used after the finished work has received a coat of sealer or friction polish.

It can be applied by light pressure of the wax block to the workpiece as it revolves in the lathe.

This will leave on the surface an evenly distributed coat of wax which is polished into the work by friction using a piece of soft cloth. The result will be a warm, eggshell sheen on the work.

Paste

The paste form of beeswax is extremely useful when polishing both flat and turned work such as is found in cabinet making.

Paste wax is best used after sealer or friction polish has been applied to the finished work. An evenly distributed coat of paste is brought to a warm sheen by burnishing with a soft cloth or shoe brush.

This practice has been used to great effect on fumed oak; a few applications produces a finish superior to that of french polish.

To make beeswax paste, mix beeswax with genuine turpentine until it reaches the consistency of butter.

You can do this two ways.

- 1 Finely shred the beeswax into the turpentine and leave overnight, which allows the two to dissolve without the use of heat. The mixture will be ready to use the following morning.
- 2 Using heat. **Care must be taken.**
Do not use direct heat as both the wax and the turpentine are highly flammable; direct heat can also de-nature the mixture.
The safest way is to place the wax and turpentine together in a container which is then placed in hot water. This method will not de-nature the mixture.

Advantages of beeswax

It is easy to apply; furniture and turned work can be quickly recoated and burnished at any time.

Disadvantages of beeswax

It has a low melting point and treated surfaces are prone to damage from damp and from sweaty fingers.

Woodturning Notes *Allan Batty*



27 – CARNAUBA WAX

THIS is a very hard, vegetable wax which is obtained from the leaves of a palm tree (*Copernicia cerifera*) which grows throughout South America. Carnauba wax has a high melting point (185° to 195°F) and is the hardest and toughest of the natural waxes. It can be applied in the same way as beeswax, after sealing the wood, and leaves a very high shine.

Advantages of carnauba wax

Since it is extremely hard, it is much more resistant to marking than is beeswax.

Disadvantages of carnauba wax

Because of the hardness of this wax it can mark the surface of the work when used on softer woods.

28 – BEESWAX/CARNAUBA WAX MIX

WE can turn the disadvantages of the two aforementioned waxes to our advantage by mixing them together.

Two parts beeswax to one of carnauba gives us the ideal wax, not so soft as to readily finger mark, and not so hard as to score our finished work. The mix is applied in the manner already described.

29 – WAX STOPPER STICKS

WHEN mixing the waxes save a portion and add artist's coloring powders to make stopper sticks of different colors. Cast them into a suitable container such as a baking tray.

The sticks are ideal for melting into cracks or imperfections in your work so as to render them invisible. Melt them using a soldering iron, a hot wire or a lit match.

For example, if a small knot is missing from the work you could melt two or three different shades of brown stopper sticks into the hole and, as each blends into the other, you will create the impression of a knot.

By experimenting you can disguise almost any defect. The beeswax/carnauba wax on its own is just the right shade for pitch pine, beech and similar colored woods.

Allan Batty Woodturning Notes



FOR many turning enthusiasts, thread chasing, that is the cutting of screw threads in wood, can be a nightmare. You have this piece of expensive, beautifully marked hardwood that you intend to turn into your masterpiece. The design demands a threaded lid and you know that just a tiny error of judgement on your part could easily ruin it.

This is the method:

Prepare a blank of hardwood which has already been parted to form the two halves which are to be threaded.

Work on the female end first. The reason will soon become plain.

Hollow out the inside of the blank to the approximate depth required for the thread, being careful to keep the sides parallel. Then cut a rebate at the bottom of the hollowed out area, about 1/8" deeper than the area to be threaded (See diagram 1). Round the sharp square end slightly to make the start of the thread cutting easier.

Approach to first cut of female thread.

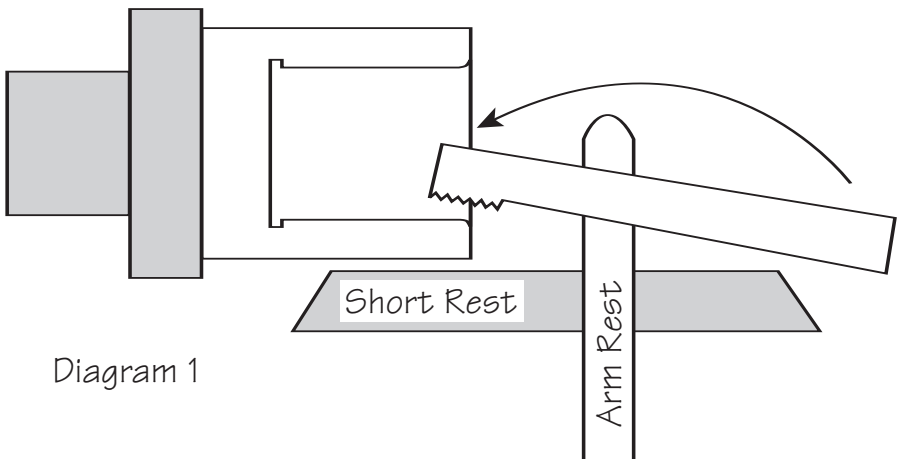

Diagram 1

Set the lathe speed to between 150 and 500 rpm – (choose the speed with which you are comfortable. Allan was working at 300 rpm)

Woodturning Notes *Allan Batty*



As indicated in the diagram, use a short rest on the lathe be set at a height so as to enable the chasing tool to be working at the center axis of the work. Using the short rest allows the chasing tool to be brought round in front of your body to start the cut. Use an arm rest across the short rest to support the tool and give you control over your action. As the thread is cut, the hook on the end of the arm rest is used to pull the chasing tool gently towards you to maintain contact with thread. It's a good idea to have a dummy run and just go through the motions first, rather like a golfer practices his swing. The feel of the whole setup is important.

For the first part of the thread cutting, run the lathe and keeping the chasing tool at an angle, allow it to touch the work at the rounded entry point and up the curve a little way then lift the tool off the work. This will create the first shallow threads. By applying the tool again, picking up the same thread and at the same time gradually squaring it up with the work, a deeper cut will be taken and the tool will start to be drawn along into the opening. It is essential that you are in control of the tool and that you lift it off the working face as soon as it gets to the end - hence the rebate at the bottom of the opening. Without the rebate, the tool would be drawn hard up against the bottom and the threads would be stripped. There is no need to be aggressive with the tool! Gently does it! After just a few passes, the thread will be cut. Make sure that the thread shape is good and true and that it fits the profile of the cutting tool.

Rounding the outer edge at the beginning means that the thread has an easier entry for the male thread to screw into when cut.

You will note that no measuring or sizing has been required. You make the female opening to whatever suits the work piece and the number of threads cut depends on that too.

If you make a mistake with the female thread, all need not be lost! Providing you leave enough wood, you can start the process again.

Now prepare the male blank.

In the blank which is to form the male thread, turn the end down forming a spigot about 1/8" deep which will just fit neatly into the threaded opening. This is the highest point of the female thread and establishes the lowest point of the male thread diameter. Then turn the rest of the material down along the appropriate length to a diameter which approximates the height of the thread to be cut (see diagram 2). It is essential to cut a rebate at the end of the area to be threaded as with the female thread.



Approach to first cut of male thread.

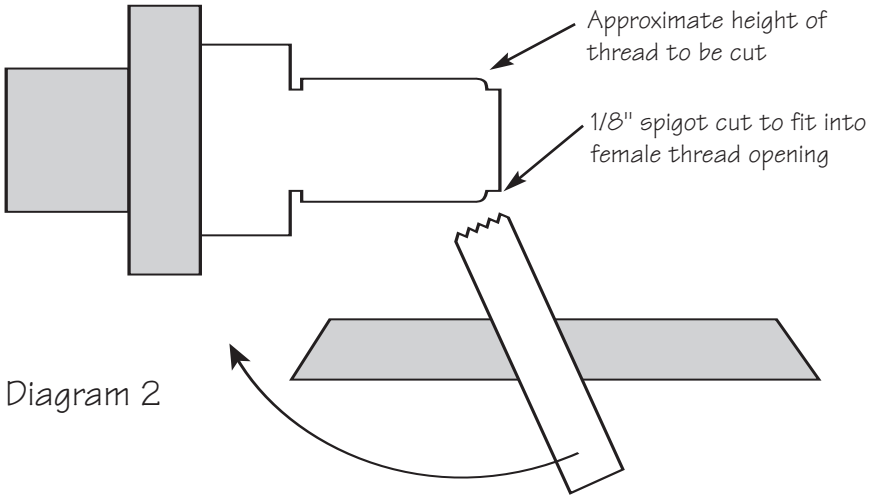

START the thread by applying the male chaser at an angle to the work and on the center axis. Gradually, bring the tool round to square on to the workpiece. Again, only a few passes will be required to form the thread. As soon as there appears a thread mark on the spigot, you know that the thread is cut to the right depth. You can then try it against the female thread. If you find that the thread is too tight, just remove a fraction from the top of the threads and re-cut it. It is often better to just turn the lathe by hand at this point so that the fit can be exact. When you are satisfied that everything is right, you can remove the spigot.

You can see that by cutting the female thread first, there is no need for calipers or careful calculations when it comes to cutting the male thread and yet there is no room for errors to be corrected. It is so much easier to work on the male part to get that to fit the female than the other way around.

The gentle approach makes the whole operation look easy and I'm sure that with a little practice, thread chasing is another skill that any enthusiast can add to their repertoire.

Woodturning Notes *Allan Batty*



Some Notes

Sizes

Thread Chasers are to be found in a number of thread types, but wood turners usually use BSW in sizes ranging from 3 threads per inch up to 40tpi. The most common sizes are 16, 18, 20 and these are the best for the learner.

Handles

The chasing tools are fitted with short handles because they are used in front of the body. Typically, the blade may be 3 1/2" and the handle 5" making the tool 8 1/2" overall.

Woods

It is best to use hardwoods for screw thread work but not all of them are suitable. Wood should be close-grained such as boxwood, ligne vitea, cocobolo, blackwood, etc.. Some hardwoods have a tendency to crumble on the tooth edge, so experiment first. You may be surprised at what works and what doesn't! Soft woods are difficult for several reasons and are best avoided altogether.

Sharpening

Thread Chasers are sharpened by hollow grinding on the top faces. Never touch the teeth. Hollow grinding allows honing. It's a good idea to round slightly, the hard square bottom edge of the chaser to enable it to slide along the rest more easily. You may also want to grind the internal tool down on it's back edge to make it thinner. (Dotted line shown in Diagram 3)

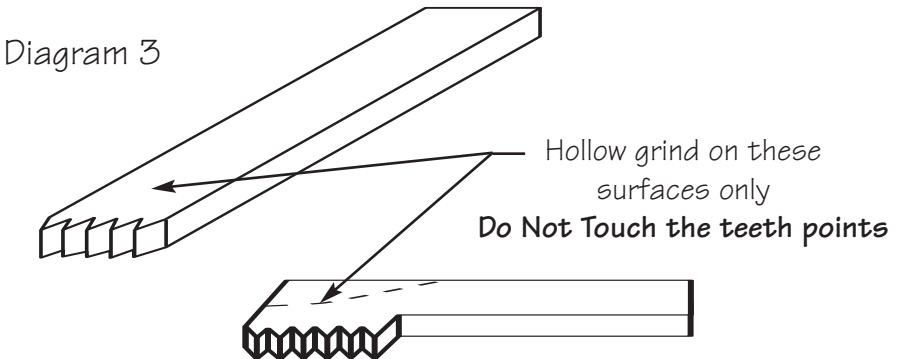

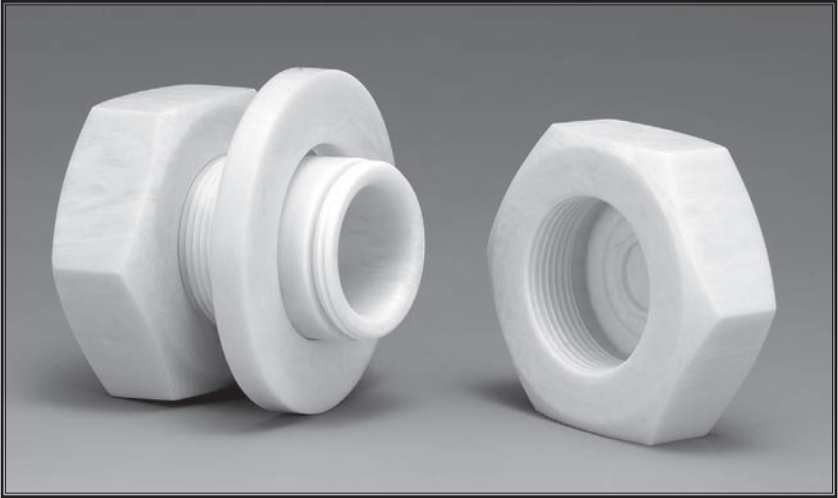

Bolt Box - by Allan Batty



CRAFT SUPPLIES USA
THE WOODTURNERS CATALOG

1-800-551-8876 • woodturnerscatalog.com